

# BRIGHTON CROSSING FILING NO. 2, 8TH AMENDMENT

A PORTION OF THE SOUTHEAST QUARTER OF SECTION 2, TOWNSHIP 1 SOUTH, RANGE 66 WEST OF THE SIXTH PRINCIPAL MERIDIAN, CITY OF BRIGHTON, COUNTY OF ADAMS, STATE OF COLORADO  
SHEET 1 OF 11

**LEGAL DESCRIPTION:**

KNOW ALL MEN BY THESE PRESENTS THAT THE UNDERSIGNED, BEING THE OWNERS OF THE PROPERTY DESCRIBED AS FOLLOWS:

A PARCEL OF LAND BEING ALL OF LOT 7, BLOCK 7, LOT 1, BLOCK 8, LOT 1, BLOCK 9, LOT 1, BLOCK 10, LOT 1, BLOCK 11, LOT 1, BLOCK 12, LOT 1, BLOCK 13, LOT 1, BLOCK 14, LOT 1, BLOCK 15, TRACT T, TRACT U, TRACT Y, PLATTE RIVER COURT, CLEAR CREEK PLACE, RUSH CREEK PLACE, YAMPA RIVER PLACE, AND PORTIONS OF LONGS PEAK STREET, COLORADO RIVER AVENUE, NORTH GOLDEN EAGLE PARKWAY, YARROW STREET, AND ROYAL PINE STREET, BRIGHTON CROSSING FILING NO. 2, 6TH AMENDMENT, RECORDED UNDER RECEPTION NO. 2018000039340, AND ALL OF TRACT Z, BRIGHTON CROSSING FILING NO. 2, RECORDED UNDER RECEPTION NO. C1074039, SITUATED IN THE SOUTHEAST QUARTER OF SECTION 2, TOWNSHIP 1 SOUTH, RANGE 66 WEST OF THE SIXTH PRINCIPAL MERIDIAN, CITY OF BRIGHTON, COUNTY OF ADAMS, STATE OF COLORADO, BEING MORE PARTICULARLY DESCRIBED AS FOLLOWS:

**COMMENCING** AT THE NORTHWEST CORNER OF SAID SECTION 2, WHENCE THE NORTH LINE OF SAID NORTHWEST QUARTER BEARS NORTH 89°15'55" EAST, A DISTANCE OF 2633.96 FEET, ALL BEARINGS HEREON ARE REFERENCED THERETO;

THENCE SOUTH 44°10'30" EAST, A DISTANCE 4210.58 FEET TO THE SOUTHERLY RIGHT-OF-WAY OF LONGS PEAK STREET AS DEPICTED ON SAID BRIGHTON CROSSING FILING NO. 2, 6TH AMENDMENT, AND THE **POINT OF BEGINNING**;

THENCE ALONG SAID SOUTHERLY RIGHT-OF-WAY THE FOLLOWING TWO (2) COURSES;

1. NORTH 82°12'44" EAST, A DISTANCE OF 57.27 FEET TO THE BEGINNING OF A TANGENT CURVE CONCAVE SOUTHWESTERLY HAVING A RADIUS OF 40.81 FEET;
2. SOUTHEASTERLY ALONG SAID CURVE THROUGH A CENTRAL ANGLE OF 97°29'57", AN ARC LENGTH OF 69.44 FEET;

THENCE DEPARTING SAID SOUTHERLY RIGHT-OF-WAY, SOUTH 73°42'54" EAST, A DISTANCE OF 41.73 FEET TO SAID SOUTHERLY RIGHT-OF-WAY AND THE BEGINNING OF A NON-TANGENT CURVE CONCAVE SOUTHEASTERLY HAVING A RADIUS OF 59.70 FEET, THE RADIUS POINT OF SAID CURVE BEARS NORTH 89°42'44";

THENCE ALONG SAID SOUTHERLY RIGHT-OF-WAY THE FOLLOWING TWO (2) COURSES;

1. NORTHEASTERLY ALONG SAID CURVE THROUGH A CENTRAL ANGLE OF 89°53'23", AN ARC LENGTH OF 93.66 FEET;
2. NORTH 89°36'06" EAST, A DISTANCE OF 219.39 FEET TO A POINT OF CUSP, CONCAVE SOUTHEASTERLY HAVING A RADIUS OF 13.00 FEET, THE RADIUS POINT OF SAID CURVE BEARS SOUTH 00°23'55" EAST, AND TO THE WESTERLY BOUNDARY OF LOT 1, BLOCK 7 AS SHOWN ON SAID BRIGHTON CROSSING FILING NO. 2, 6TH AMENDMENT;

THENCE ALONG THE WESTERLY, SOUTHERLY, AND EASTERLY BOUNDARIES OF LOTS 1-6, INCLUSIVE, BLOCK 7 THE FOLLOWING FIVE (5) COURSES;

1. SOUTHWESTERLY ALONG SAID CURVE THROUGH A CENTRAL ANGLE OF 89°53'21", AN ARC LENGTH OF 20.40 FEET;
2. NORTH 89°31'48" EAST, A DISTANCE OF 40.00 FEET
3. SOUTH 00°17'16" EAST, A DISTANCE OF 107.07 FEET;
4. NORTH 89°42'44" EAST, A DISTANCE OF 353.00 FEET;
5. NORTH 00°17'16" WEST, A DISTANCE OF 120.72 FEET TO SAID SOUTHERLY RIGHT-OF-WAY;

THENCE ALONG SAID SOUTHERLY RIGHT-OF-WAY THE FOLLOWING TWO (2) COURSES;

1. NORTH 89°36'06" EAST, A DISTANCE OF 104.92 FEET TO THE BEGINNING OF A TANGENT CURVE CONCAVE SOUTHWESTERLY HAVING A RADIUS OF 13.00 FEET;
2. SOUTHEASTERLY ALONG SAID CURVE THROUGH A CENTRAL ANGLE OF 90°06'37", AN ARC LENGTH OF 20.45 FEET;

THENCE DEPARTING SAID SOUTHERLY RIGHT-OF-WAY, NORTH 89°31'48" EAST, A DISTANCE OF 40.00 FEET TO SAID SOUTHERLY RIGHT-OF-WAY AND THE BEGINNING OF A NON-TANGENT CURVE CONCAVE SOUTHEASTERLY HAVING A RADIUS OF 13.00 FEET, THE RADIUS POINT OF SAID CURVE BEARS NORTH 89°42'44" EAST;

THENCE ALONG SAID SOUTHERLY RIGHT-OF-WAY THE FOLLOWING TWO (2) COURSES;

1. NORTHEASTERLY ALONG SAID CURVE THROUGH A CENTRAL ANGLE OF 89°53'23", AN ARC LENGTH OF 20.40 FEET;
2. NORTH 89°36'06" EAST, A DISTANCE OF 286.54 FEET TO THE EASTERLY BOUNDARY OF SAID BRIGHTON CROSSING FILING NO. 2, 6TH AMENDMENT;

THENCE ALONG SAID EASTERLY BOUNDARY THE FOLLOWING FOUR (4) COURSES;

1. SOUTH 00°40'02" EAST, A DISTANCE OF 1129.72 FEET;
2. SOUTH 89°21'16" WEST, A DISTANCE OF 1005.88 FEET;
3. SOUTH 34°53'38" WEST, A DISTANCE OF 73.28 FEET;
4. SOUTH 13°16'10" WEST, A DISTANCE OF 519.77 FEET TO THE NORTHEAST CORNER OF SAID TRACT Z, BRIGHTON CROSSING FILING NO. 2;

THENCE ALONG THE EASTERLY, SOUTHERLY, AND WESTERLY BOUNDARY OF SAID TRACT Z THE FOLLOWING FIVE (5) COURSES;

1. SOUTH 13°16'10" WEST, A DISTANCE OF 16.97 FEET;
2. SOUTH 13°28'57" EAST, A DISTANCE OF 137.26 FEET;
3. SOUTH 89°21'16" WEST, A DISTANCE OF 109.65 FEET;
4. NORTH 00°20'10" WEST, A DISTANCE OF 26.09 FEET;
5. NORTH 00°12'45" WEST, A DISTANCE OF 124.22 FEET TO THE SOUTHWEST CORNER OF SAID BRIGHTON CROSSING FILING NO. 2, 6TH AMENDMENT;

THENCE ALONG THE WESTERLY BOUNDARY OF SAID BRIGHTON CROSSING FILING NO. 2, 6TH AMENDMENT THE FOLLOWING FIFTEEN (15) COURSES;

1. NORTH 00°12'45" WEST, A DISTANCE OF 50.78 FEET;
2. NORTH 01°42'19" WEST, A DISTANCE OF 115.17 FEET;
3. NORTH 00°12'45" WEST, A DISTANCE OF 330.00 FEET;
4. NORTH 85°18'02" EAST, A DISTANCE OF 33.47 FEET;
5. NORTH 02°42'49" WEST, A DISTANCE OF 109.50 FEET;
6. NORTH 87°17'11" EAST, A DISTANCE OF 4.15 FEET;
7. NORTH 02°42'49" WEST, A DISTANCE OF 145.50 FEET;
8. SOUTH 87°17'11" WEST, A DISTANCE OF 16.40 FEET;
9. NORTH 00°12'45" WEST, A DISTANCE OF 427.60 FEET;
10. SOUTH 88°49'07" EAST, A DISTANCE OF 5.52 FEET;
11. NORTH 01°10'53" EAST, A DISTANCE OF 36.00 FEET;
12. NORTH 88°49'07" WEST, A DISTANCE OF 6.39 FEET;
13. NORTH 00°12'45" WEST, A DISTANCE OF 348.24 FEET;
14. NORTH 86°25'05" EAST, A DISTANCE OF 31.82 FEET;
15. NORTH 07°47'16" WEST, A DISTANCE OF 119.50 FEET TO THE **POINT OF BEGINNING**;

CONTAINING AN AREA OF 33.248 ACRES, (1,448,296 SQUARE FEET), MORE OR LESS.

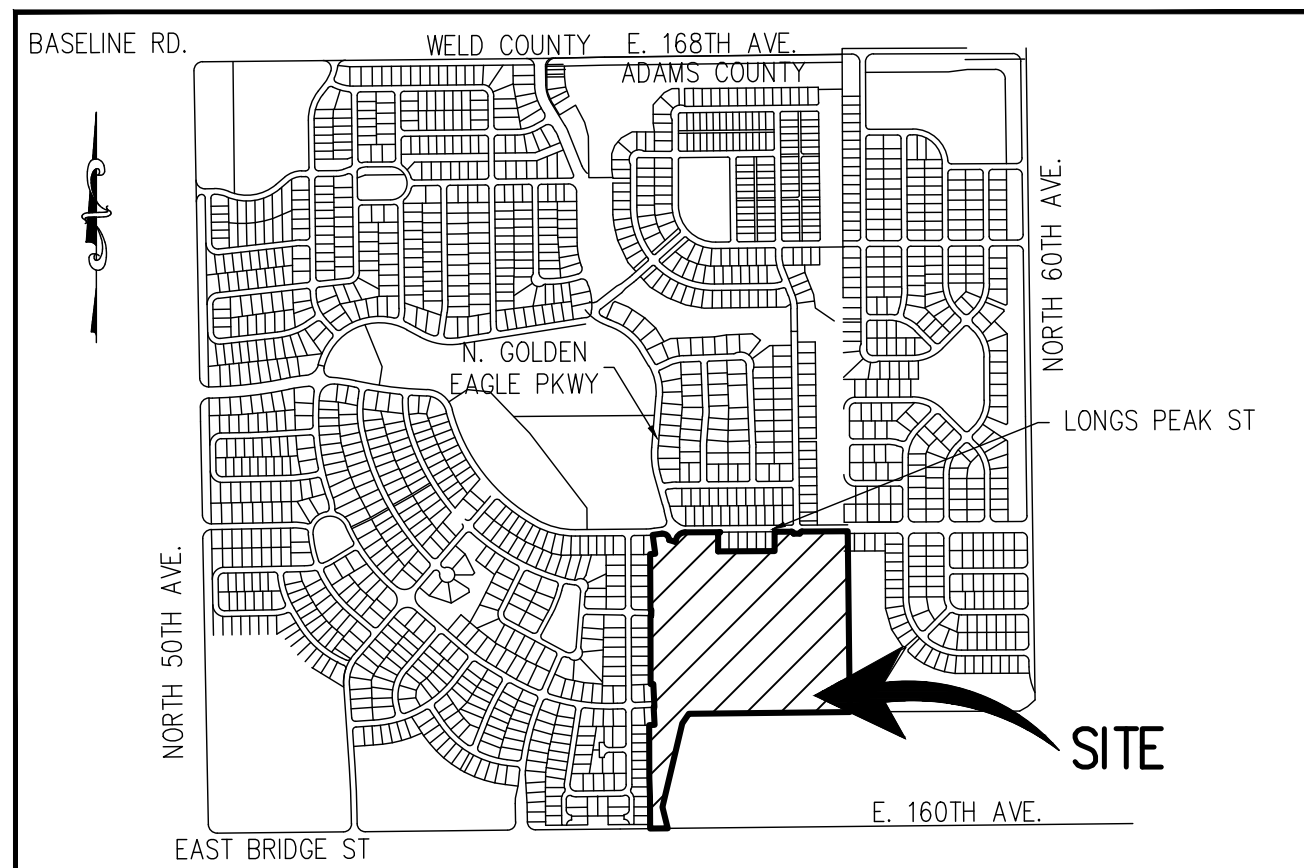

**VICINITY MAP**  
NOT TO SCALE

**DEDICATION:**

HAVE BY THESE PRESENTS LAID OUT, PLATTED AND SUBDIVIDED THE SAME INTO LOTS, BLOCKS, STREETS AND TRACTS AS SHOWN ON THIS PLAT UNDER THE NAME AND STYLE OF **BRIGHTON CROSSING FILING NO. 2, 8TH AMENDMENT** AND DO HEREBY GRANT TO THE CITY OF BRIGHTON, COUNTY OF ADAMS, STATE OF COLORADO, FOR THE USE OF THE PUBLIC, TRACTS, THE PUBLIC WAYS AND LANDS HEREON SHOWN, AND THE EASEMENTS AS SHOWN FOR DRAINAGE AND DETENTION.

**OWNER:**

BROOKFIELD RESIDENTIAL (COLORADO) LLC, A NEVADA LIMITED LIABILITY COMPANY

BY: \_\_\_\_\_ AS \_\_\_\_\_  
NAME TITLE

STATE OF \_\_\_\_\_ )  
COUNTY OF \_\_\_\_\_ ) SS

THE FOREGOING DEDICATION AND OWNERSHIP WAS ACKNOWLEDGED BEFORE ME THIS \_\_\_\_ DAY OF \_\_\_\_\_, 20\_\_\_\_, BY \_\_\_\_\_ AS \_\_\_\_\_ OF

BROOKFIELD RESIDENTIAL (COLORADO) LLC, A NEVADA LIMITED LIABILITY COMPANY

WITNESS MY HAND AND OFFICIAL SEAL.

MY COMMISSION EXPIRES: \_\_\_\_\_

\_\_\_\_\_  
NOTARY PUBLIC

**OWNER:**

BRIGHTON CROSSING METROPOLITAN DISTRICT NO. 7, A COLORADO SPECIAL DISTRICT

BY: \_\_\_\_\_ AS \_\_\_\_\_  
NAME TITLE

STATE OF \_\_\_\_\_ )  
COUNTY OF \_\_\_\_\_ ) SS

THE FOREGOING DEDICATION AND OWNERSHIP WAS ACKNOWLEDGED BEFORE ME THIS \_\_\_\_ DAY OF \_\_\_\_\_, 20\_\_\_\_, BY \_\_\_\_\_ AS \_\_\_\_\_ OF

BRIGHTON CROSSING METROPOLITAN DISTRICT NO. 7, A COLORADO SPECIAL DISTRICT

WITNESS MY HAND AND OFFICIAL SEAL.

MY COMMISSION EXPIRES: \_\_\_\_\_

\_\_\_\_\_  
NOTARY PUBLIC

**SHEET INDEX**

- SHEET 1 COVER SHEET
- SHEET 2 GENERAL NOTES & TABLES
- SHEET 3 OVERALL LAYOUT
- SHEETS 4-10 LOT DETAILS
- SHEET 11 LINE & CURVE TABLES

**PURPOSE:**

THE PURPOSE OF THIS AMENDMENT IS TO AMEND ALL OF LOT 7, BLOCK 7, LOT 1, BLOCK 8, LOT 1, BLOCK 9, LOT 1, BLOCK 10, LOT 1, BLOCK 11, LOT 1, BLOCK 12, LOT 1, BLOCK 13, LOT 1, BLOCK 14, LOT 1, BLOCK 15, TRACT T, TRACT U, TRACT Y, PLATTE RIVER COURT, CLEAR CREEK PLACE, RUSH CREEK PLACE, YAMPA RIVER PLACE, AND PORTIONS OF LONGS PEAK STREET, COLORADO RIVER AVENUE, NORTH GOLDEN EAGLE PARKWAY, YARROW STREET, AND ROYAL PINE STREET, BRIGHTON CROSSING FILING NO. 2, 6TH AMENDMENT, RECORDED UNDER RECEPTION NO. 2018000039340, AND ALL OF TRACT Z, BRIGHTON CROSSING FILING NO. 2, RECORDED UNDER RECEPTION NO. C1074039, SITUATED IN THE SOUTHEAST QUARTER OF SECTION 2, TOWNSHIP 1 SOUTH, RANGE 66 WEST OF THE SIXTH PRINCIPAL MERIDIAN, CITY OF BRIGHTON, COUNTY OF ADAMS, STATE OF COLORADO.

**NOTICE IS HEREBY GIVEN:**

1. ANY CONSTRUCTION ACROSS EXISTING SUBDIVISION LOT LINES IS IN VIOLATION OF THE SUBDIVISION REGULATIONS OF THE CITY.
2. ANY DIVISION OF AN EXISTING SUBDIVISION LOT, OR CONVEYANCE OF A PART OF AN EXISTING SUBDIVISION LOT VIOLATES THE CITY SUBDIVISION REGULATIONS UNLESS 1) APPROVED BY THE CITY OF BRIGHTON, OR 2) IS EXCEPTED FROM THE DEFINITION OF "SUBDIVISION" AS APPROVED BY THE SUBDIVISION REGULATIONS.

**SURVEYOR'S CERTIFICATE**

I, ANTHONY K. PEALL, A DULY LICENSED PROFESSIONAL LAND SURVEYOR, REGISTERED IN THE STATE OF COLORADO DO HEREBY CERTIFY THAT THERE ARE NO ROADS, PIPELINES, IRRIGATION DITCHES, OR OTHER EASEMENTS IN EVIDENCE OR KNOWN BY ME TO EXIST ON OR ACROSS THE HEREIN BEFORE DESCRIBED PROPERTY EXCEPT AS SHOWN ON THIS PLAT. I FURTHER CERTIFY THAT I HAVE PERFORMED THE SURVEY SHOWN HEREON, OR SUCH SURVEY WAS PREPARED UNDER MY DIRECT RESPONSIBILITY AND SUPERVISION, THAT THIS PLAT ACCURATELY REPRESENTS SAID SURVEY, AND THAT ALL MONUMENTS EXIST AS SHOWN HEREIN.

ANTHONY K. PEALL  
COLORADO LICENSED PROFESSIONAL LAND SURVEYOR, P.L.S. 38636  
FOR AND ON BEHALF OF AZTEC CONSULTANTS, INC.  
300 E. MINERAL AVE., SUITE 1  
LITTLETON, CO. 80122  
(303) 713-1897

**NOTICE:** ACCORDING TO COLORADO LAW, YOU MUST COMMENCE ANY LEGAL ACTION BASED UPON ANY DEFECT IN THIS SURVEY WITHIN THREE YEARS AFTER YOU FIRST DISCOVER SUCH DEFECT. IN NO EVENT, MAY ANY ACTION BASED UPON ANY DEFECT IN THIS SURVEY BE COMMENCED MORE THAN TEN YEARS FROM THE DATE OF THE CERTIFICATION SHOWN HEREON.

**NOTICE:** PER THE STATE OF COLORADO BOARD OF LICENSURE FOR ARCHITECTS, PROFESSIONAL ENGINEERS, AND PROFESSIONAL LAND SURVEYORS RULE 6.2.2 THE WORD "CERTIFY" AS USED HEREON MEANS AN EXPRESSION OF PROFESSIONAL OPINION AND DOES NOT CONSTITUTE A WARRANTY OR GUARANTEE, EXPRESSED OR IMPLIED. THE SURVEY REPRESENTED HEREON HAS BEEN PERFORMED BY ME OR UNDER MY DIRECT SUPERVISION IN ACCORDANCE WITH APPLICABLE STANDARDS OF PRACTICE AND IS BASED UPON MY KNOWLEDGE, INFORMATION AND BELIEF.

**ATTORNEY'S CERTIFICATE:**

I, \_\_\_\_\_, AN ATTORNEY AT LAW, DO HEREBY CERTIFY THAT I HAVE EXAMINED THE TITLE TO ALL OF THE LAND PLATTED HEREON AND THAT TITLE TO SUCH LANDS IS IN THE DEDICATORS FREE AND CLEAR OF ALL LIENS, TAXES, AND ENCUMBRANCES, SUBJECT TO ALL MATTERS AS REFLECTED IN SCHEDULE B-2 OF PROPERTY INFORMATION BINDER ORDER NO. \_\_\_\_\_ EFFECTIVE DATE OF \_\_\_\_\_, ISSUED BY LAND TITLE GUARANTEE COMPANY.

ATTORNEY AT LAW \_\_\_\_\_ DATE \_\_\_\_\_

REGISTRATION NO. \_\_\_\_\_

**CITY COUNCIL APPROVAL:**

THIS IS TO CERTIFY THAT THIS PLAT AMENDMENT WAS ACCEPTED AND APPROVED BY THE CITY COUNCIL OF THE CITY OF BRIGHTON, COLORADO ON THE \_\_\_\_\_ DAY OF \_\_\_\_\_, 20\_\_\_\_.

MAYOR: GREGORY MILLS

CITY CLERK: NATALIE HOEL

**AZTEC** CONSULTANTS, INC.  
300 East Mineral Ave., Suite 1  
Littleton, Colorado 80122  
Phone: (303) 713-1898  
Fax: (303) 713-1897  
www.aztecconsultants.com  
Drawn By: BAM

DATE OF PREPARATION:	08-21-2019
SCALE:	N/A
SHEET 1 OF 11	

# BRIGHTON CROSSING FILING NO. 2, 8TH AMENDMENT

A PORTION OF THE SOUTHEAST QUARTER OF SECTION 2, TOWNSHIP 1 SOUTH, RANGE 66 WEST OF  
THE SIXTH PRINCIPAL MERIDIAN, CITY OF BRIGHTON, COUNTY OF ADAMS, STATE OF COLORADO  
SHEET 2 OF 11

**GENERAL NOTES:**

1. ANY PERSON WHO KNOWINGLY REMOVES, ALTERS OR DEFACTS ANY PUBLIC LAND SURVEY MONUMENT OR ACCESSORY COMMITS A CLASS TWO (2) MISDEMEANOR PURSUANT TO STATE STATUTE 18-4-508, C.R.S.
2. THIS SURVEY RELIES ON LAND TITLE GUARANTEE COMPANY REPRESENTING OLD REPUBLIC NATIONAL TITLE INSURANCE COMPANY PROPERTY INFORMATION BINDER ORDER NO. PIB70634614.2145519 EFFECTIVE DATE OF MAY 7, 2020 AT 5:00 P.M. NO TITLE SEARCH WAS MADE BY AZTEC CONSULTANTS, INC. TO DETERMINE OWNERSHIP, EASEMENTS, OR OTHER MATTERS OF RECORD.
3. BASIS OF BEARING: A PORTION OF THE NORTH LINE OF THE NORTHWEST QUARTER OF SECTION 2, TOWNSHIP 1 SOUTH, RANGE 66 WEST OF THE SIXTH PRINCIPAL MERIDIAN, BEING MONUMENTED AT THE WEST END (NORTHWEST CORNER OF SAID SECTION 2, TOWNSHIP 1 SOUTH, RANGE 66 WEST OF THE SIXTH PRINCIPAL MERIDIAN) BY A 2" ILLEGIBLE ALUMINUM CAP IN RANGE BOX AND AT THE EAST END (NORTH QUARTER CORNER OF SECTION 2, T1N, R66W) BY A 3 1/4" ILLEGIBLE ALUMINUM CAP AND ASSUMED TO BEAR NORTH 89°19'55" EAST, A DISTANCE OF 2633.96 FEET.
4. THE SURVEYED PROPERTY SHOWN HEREIN LIES WITHIN OTHER AREAS, FLOOD ZONE "X", AREAS DETERMINED TO BE OUTSIDE THE 0.2% ANNUAL CHANCE FLOODPLAIN, PER FEDERAL EMERGENCY MANAGEMENT AGENCY FLOOD INSURANCE RATE MAP (FIRM) NO. 08001C0355H, WITH A REVISED DATE OF MARCH 5, 2007. DETERMINATION OF FLOOD ZONE CLASSIFICATION IS DEPICTED BY SCALED MAP LOCATION AND GRAPHIC PLOTTING ONLY.
5. ALL DEDICATIONS AND GRANTS MADE TO THE CITY OF BRIGHTON ARE SUBJECT TO THE TERMS, CONDITIONS, AND RESTRICTIONS OF THE ANNEXATION AGREEMENT AND ALL THE AMENDMENTS THERETO AS EVIDENCED BY THE INSTRUMENTS RECORDED APRIL 13, 1987 IN BOOK 3301 AT PAGE 899, NOVEMBER 14, 1994 IN BOOK 4423 AT PAGE 908, NOVEMBER 20, 1995 IN BOOK 4630 AT PAGE 395, JUNE 19, 1996 IN BOOK 4776 AT PAGE 140, AND NOVEMBER 21, 1997 IN BOOK 5163 AT PAGE 219 IN THE RECORDS OF THE ADAMS COUNTY CLERK AND RECORDER'S OFFICE.
6. APPROVAL OF THIS DOCUMENT MAY CREATE A VESTED PROPERTY RIGHT PURSUANT TO ARTICLE 68 OF TITLE 24, COLORADO REVISED STATUTES AS AMENDED
7. PER C.R.S. 38-51-106, "ALL LINEAL UNITS DEPICTED ON THIS LAND SURVEY PLAT ARE U.S. SURVEY FEET. ONE METER EQUALS 39.37/12 U.S. SURVEY FEET, EXACTLY ACCORDING TO THE NATIONAL INSTITUTE OF STANDARDS AND TECHNOLOGY."
8. THIS PLAT IS SUBJECT TO THAT SPEER CANAL EASEMENT RECORDED IN BOOK 87 AT PAGES 167 & 168 ALONG WITH THAT GAS PIPELINE RIGHT OF WAY UNDER THE SPEER CANAL AS DESCRIBED IN BOOK 362 AT PAGE 292 IN SAID RECORDS.
9. THIS PLAT IS SUBJECT TO THAT MASTER UTILITY EASEMENT AGREEMENT RECORDED UNDER RECEPTION NO. C0355284 IN SAID RECORDS.
10. THIS PLAT IS SUBJECT TO THAT SEEPAGE EASEMENT AGREEMENT RECORDED UNDER RECEPTION NO. 2016000045409 IN SAID RECORDS.
11. THIS PLAT SUPERCEDES AND REPLACES THE BRIGHTON CROSSING FILING NO. 2, 6TH AMENDMENT SUBDIVISION PLAT FOR THE PROPERTY WITHIN THE BOUNDARY OF THIS PLAT.
12. THE DRAINAGE/ACCESS EASEMENT IS FOR PURPOSES OF INSPECTION AND ASSURANCE OF COMPLIANCE TO THE CITY OF BRIGHTON MUNICIPAL CODE. MAINTENANCE, REPAIR, AND LONG TERM FUNCTION OF THE DRAINAGE FACILITIES WILL BE THE ON-GOING RESPONSIBILITY OF THE PROPERTY OWNER.

SUBDIVISION DATA TABLE		
DESCRIPTION	NUMBER	ACRES
LOTS	161	19.673 ACRES
SUPER LOTS	2	2.199 ACRES
TRACTS	12	5.822 ACRES
ROW	1	5.554 ACRES
<b>TOTAL</b>		<b>33.248 ACRES</b>

TRACT SUMMARY TABLE				
TRACT	AREA (SQ.FT)	AREA (AC ±)	USE	OWNED BY / MAINTAINED BY
TRACT QQ	2,723	0.063	LANDSCAPE	BCMD7 <sup>1</sup> / BCMD7 <sup>1</sup>
TRACT SS	3,312	0.076	LANDSCAPE	BCMD7 <sup>1</sup> / BCMD7 <sup>1</sup>
TRACT TT	5,799	0.133	LANDSCAPE	BCMD7 <sup>1</sup> / BCMD7 <sup>1</sup>
TRACT UU	6,422	0.147	LANDSCAPE	BCMD7 <sup>1</sup> / BCMD7 <sup>1</sup>
TRACT VV	6,952	0.160	LANDSCAPE	BCMD7 <sup>1</sup> / BCMD7 <sup>1</sup>
TRACT WW	6,299	0.145	LANDSCAPE	BCMD7 <sup>1</sup> / BCMD7 <sup>1</sup>
TRACT XX	3,818	0.088	LANDSCAPE	BCMD7 <sup>1</sup> / BCMD7 <sup>1</sup>
TRACT YY	2,404	0.055	LANDSCAPE	BCMD7 <sup>1</sup> / BCMD7 <sup>1</sup>
TRACT ZZ	9,600	0.220	LANDSCAPE	BCMD7 <sup>1</sup> / BCMD7 <sup>1</sup>
TRACT AAA	9,520	0.219	LANDSCAPE	BCMD7 <sup>1</sup> / BCMD7 <sup>1</sup>
TRACT T	179,680	4.125	LANDSCAPE	BCMD7 <sup>1</sup> / BCMD7 <sup>1</sup> & SBDMD
TRACT Z	17,026	0.391	LANDSCAPE	BROOKFIELD RESIDENTIAL
<b>TOTAL</b>	<b>253,555</b>	<b>5.822</b>		

SBDMD = SOUTH BEEBE DRAW METRO DISTRICT  
 BCMD7 = BRIGHTON CROSSING METRO DISTRICT NO. 7  
 1 - BCMD7 OR TITLE 32 METRO DISTRICT SERVING THE BRIGHTON CROSSING DEVELOPMENT.

**RESIDENTIAL / SINGLE FAMILY NOTES:**

1. A NON-EXCLUSIVE TEN (10) AND THIRTEEN (13) FOOT WIDE EASEMENT IS GRANTED AT RECEPTION NO. \_\_\_\_\_ FOR THE USE OF ELECTRIC, TELEPHONE CABLE, TELEVISION, PEDESTRIAN SIDEWALKS AND POSTAL FACILITIES. OTHER UTILITIES INCLUDING SANITARY SERVICE LINES, WATER SERVICE LINES, GAS LINES AND WATER METER PITS, SHALL HAVE THE RIGHT TO CROSS AT SUBSTANTIALLY RIGHT ANGLES, BUT IN NO EVENT SHALL OTHER STRUCTURES BE ALLOWED IN THE ABOVE DESCRIBED AREAS. CONCRETE DRIVEWAYS ARE PERMISSIBLE AS LONG AS THEY CROSS AT SUBSTANTIALLY RIGHT ANGLES AND DO NOT EXCEED 32 FEET IN WIDTH. CITY FACILITIES SHALL BE ALLOWED IN THE EASEMENT.
2. A NON-EXCLUSIVE FIVE (5) FOOT WIDE GAS EASEMENT IS GRANTED AT RECEPTION NO. \_\_\_\_\_. OTHER UTILITIES INCLUDING SANITARY SERVICE LINES AND WATER SERVICE LINES SHALL HAVE THE RIGHT TO CROSS AT SUBSTANTIALLY RIGHT ANGLES, BUT IN NO EVENT SHALL OTHER STRUCTURES BE ALLOWED IN THE ABOVE DESCRIBED AREA. CONCRETE DRIVEWAYS AND SIDEWALKS ARE PERMISSIBLE AS LONG AS THEY CROSS AT SUBSTANTIALLY RIGHT ANGLES AND DO NOT EXCEED 32 FEET IN WIDTH.

FOR AND ON BEHALF OF  
AZTEC CONSULTANTS, INC

<p style="font-size: 8px; margin: 0;">300 East Mineral Ave., Suite 1 Littleton, Colorado 80122 Phone: (303) 713-1898 Fax: (303) 713-1897 <a href="http://www.aztecconsultants.com">www.aztecconsultants.com</a></p> <p style="font-size: 8px; margin: 0;">AzTec Proj. No.: 69718-12      Drawn By: BAM</p>	DATE OF PREPARATION:	08-21-2019
	SCALE:	N/A
SHEET 2 OF 11		

# BRIGHTON CROSSING FILING NO. 2, 8TH AMENDMENT

A PORTION OF THE SOUTHEAST QUARTER OF SECTION 2, TOWNSHIP 1 SOUTH, RANGE 66 WEST OF THE SIXTH PRINCIPAL MERIDIAN, CITY OF BRIGHTON, COUNTY OF ADAMS, STATE OF COLORADO  
SHEET 3 OF 11

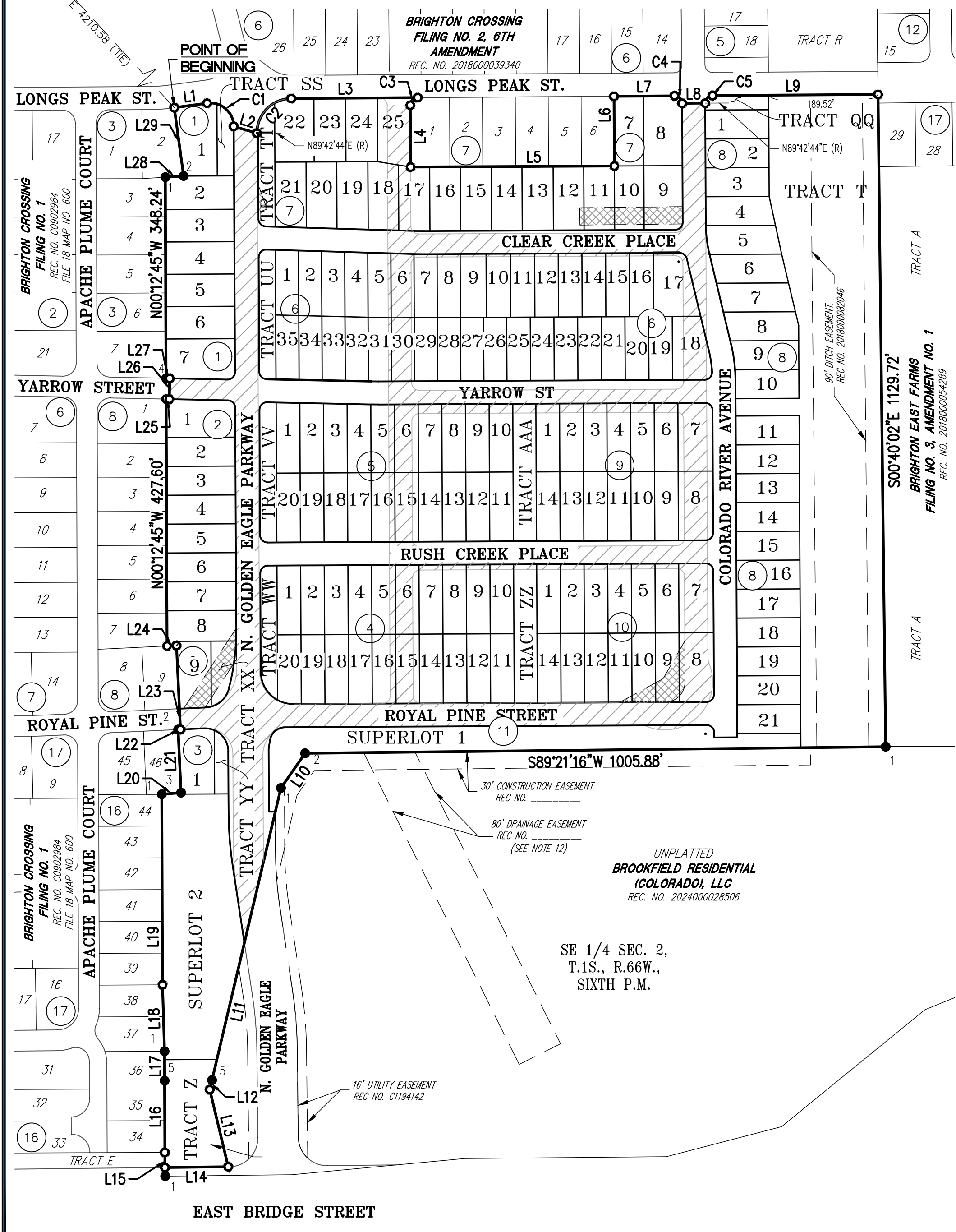
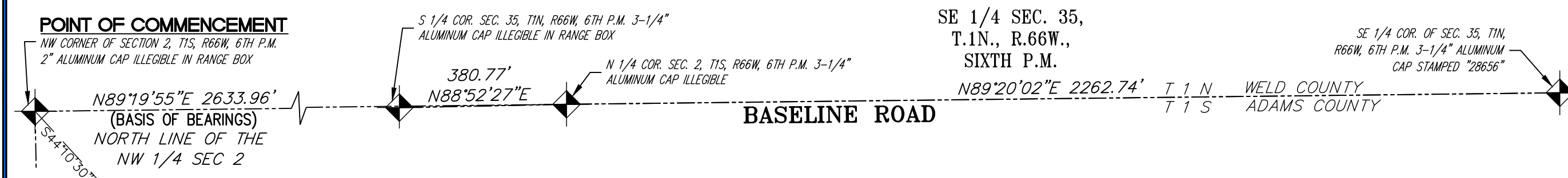

LINE	BEARING	LENGTH
L1	N82°12'47\"E	57.27'
L2	S73°42'54\"E	41.73'
L3	N89°36'06\"E	219.39'
L4	S00°17'16\"E	107.07'
L5	N89°42'44\"E	353.00'
L6	N00°17'16\"W	120.72'
L7	N89°36'06\"E	104.92'
L8	N89°31'48\"E	40.00'

LINE	BEARING	LENGTH
L9	N89°36'06\"E	286.54'
L10	S34°53'38\"W	73.28'
L11	S13°16'10\"W	519.77'
L12	S13°16'10\"W	16.97'
L13	S13°28'57\"E	137.26'
L14	S89°21'16\"W	109.65'
L15	N00°20'10\"W	26.09'
L16	N00°12'45\"W	124.22'

LINE	BEARING	LENGTH
L17	N00°12'45\"W	50.78'
L18	N01°42'19\"W	115.17'
L19	N00°12'45\"W	330.00'
L20	N85°18'02\"E	33.47'
L21	N02°42'49\"W	109.50'
L22	N87°17'11\"E	4.15'
L23	N02°42'49\"W	145.50'
L24	S87°17'11\"W	16.40'

LINE	BEARING	LENGTH
L25	S88°49'07\"E	5.52'
L26	N01°10'53\"E	36.00'
L27	N88°49'07\"W	6.39'
L28	N86°25'05\"E	31.82'
L29	N07°47'16\"W	119.50'

CURVE	DELTA	RADIUS	LENGTH
C1	97°29'57\"	40.81'	69.44'
C2	61°12'26\"	59.70'	63.77'
C3	89°53'21\"	13.00'	20.40'
C4	90°06'37\"	13.00'	20.45'
C5	89°53'23\"	12.76'	20.40'

**LEGEND**

(R) = RADIAL BEARING  
 U.E. = UTILITY EASEMENT  
 D.E. = DRAINAGE EASEMENT  
 G.E. = GAS EASEMENT  
 A.E. = ACCESS EASEMENT

RIGHT-OF-WAY TO BE VACATED BY THIS PLAT

EASEMENTS UNDER REC NO. 2018000039340 TO BE VACATED BY THIS PLAT

**MONUMENT SYMBOL LEGEND**

- FOUND NO. 5 REBAR WITH 1-1/4" ORANGE PLASTIC CAP STAMPED "PLS 28286"
- FOUND NO. 5 REBAR WITH NO CAP
- FOUND NO. 5 BENT REBAR WITH NO CAP
- FOUND NO. 5 REBAR WITH 1-1/4" ORANGE PLASTIC CAP ILLEGIBLE
- FOUND NO. 5 REBAR WITH 1-1/4" ORANGE PLASTIC CAP STAMPED "AZTEC LS 38064"
- SET NO. 5 REBAR WITH 1-1/4" PINK PLASTIC CAP STAMPED "AZTEC LS 38636"

FOUND SECTION CORNER AS SHOWN HEREON

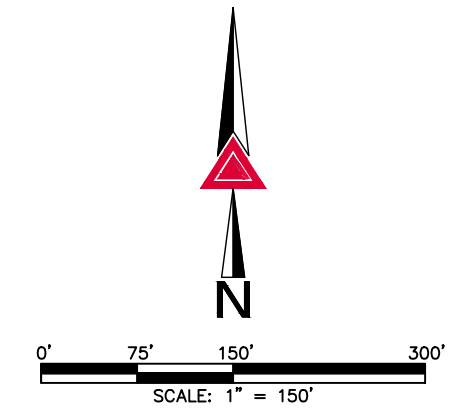

**AZTEC**  
CONSULTANTS, INC.

300 East Mineral Ave., Suite 1  
 Littleton, Colorado 80122  
 Phone: (303) 713-1898  
 Fax: (303) 713-1897  
 www.aztecconsultants.com

AzTec Proj. No.: 69718-12  
 Drawn By: BAM

DATE OF PREPARATION:	08-21-2019
SCALE:	1" = 150'
SHEET 3 OF 11	

FOR AND ON BEHALF OF  
AZTEC CONSULTANTS, INC

# BRIGHTON CROSSING FILING NO. 2, 8TH AMENDMENT

A PORTION OF THE SOUTHEAST QUARTER OF SECTION 2, TOWNSHIP 1 SOUTH, RANGE 66 WEST OF THE SIXTH PRINCIPAL MERIDIAN, CITY OF BRIGHTON, COUNTY OF ADAMS, STATE OF COLORADO

SHEET 4 OF 11

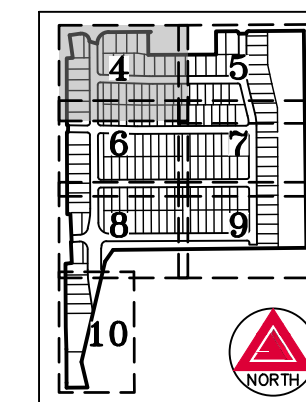
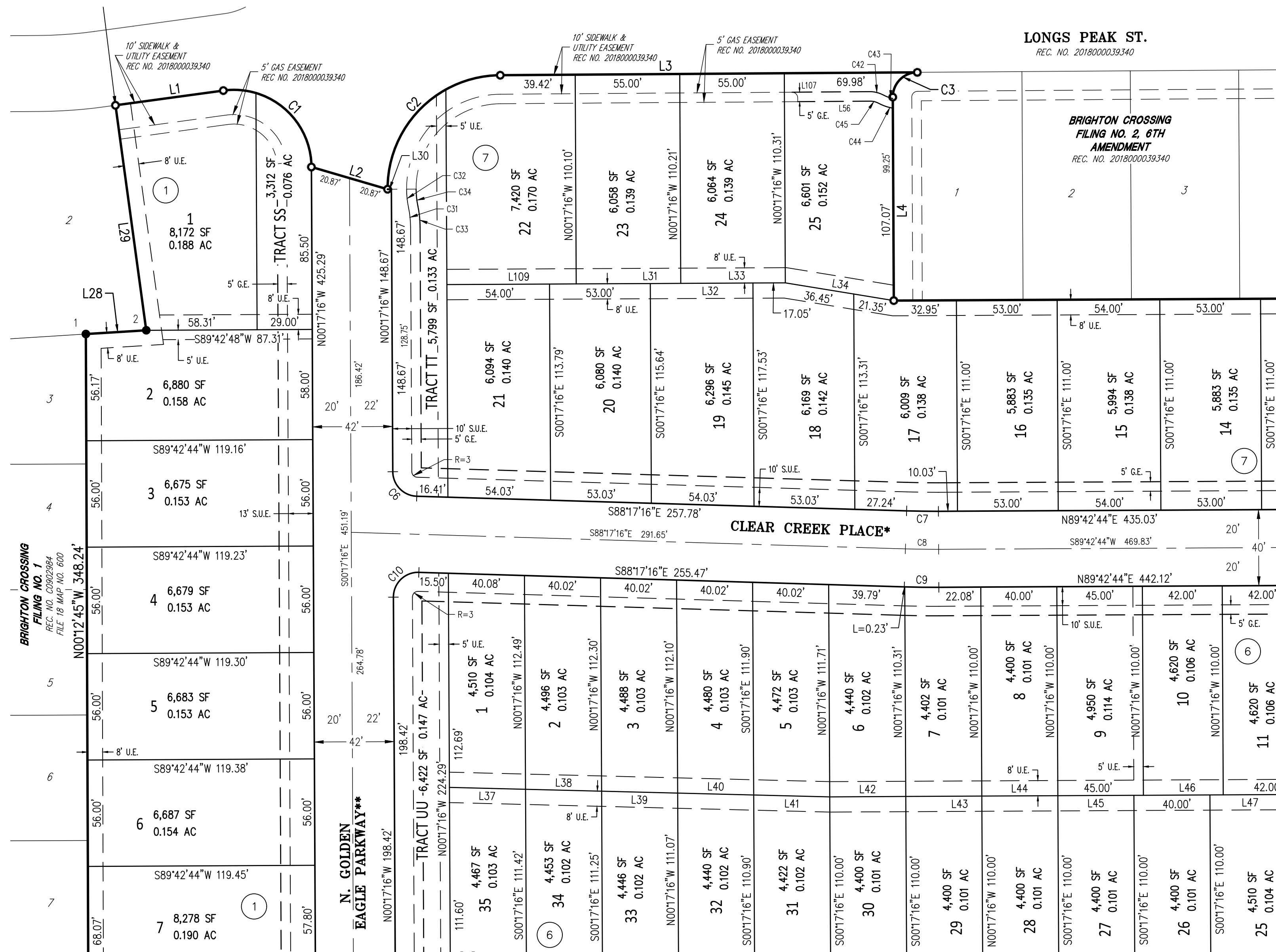

SEE SHEET 5

### LEGEND

- SET NO. 5 REBAR WITH 1-1/4" PINK PLASTIC CAP STAMPED "AZTEC LS 38636"
- FOUND NO. 5 REBAR WITH 1-1/4" ORANGE PLASTIC CAP STAMPED "PLS 28286"
- FOUND NO. 5 REBAR WITH NO CAP
- FOUND NO. 5 REBAR WITH 1-1/4" ORANGE PLASTIC CAP ILLEGIBLE

G.E. GAS EASEMENT  
U.E. UTILITY EASEMENT  
S.U.E. SIDEWALK & UTILITY EASEMENT

\* 40' WIDE PUBLIC RIGHT-OF-WAY  
\*\* PUBLIC RIGHT-OF-WAY WIDTH VARIES  
R= RADIUS OF UTILITY EASEMENT  
Ⓝ BLOCK NUMBER

SEE SHEET 11 FOR LINE & CURVE TABLES

SEE SHEET 5



SEE SHEET 6

SEE SHEET 6

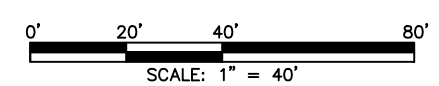

FOR AND ON BEHALF OF AZTEC CONSULTANTS, INC.

**AZTEC**  
CONSULTANTS, INC.

300 East Mineral Ave., Suite 1  
Littleton, Colorado 80122  
Phone: (303) 713-1898  
Fax: (303) 713-1897  
www.aztecconsultants.com

AzTec Proj. No.: 69718-12  
Drawn By: BAM

DATE OF PREPARATION:	08-21-2019
SCALE:	1" = 40'
SHEET 4 OF 11	

# BRIGHTON CROSSING FILING NO. 2, 8TH AMENDMENT

A PORTION OF THE SOUTHEAST QUARTER OF SECTION 2, TOWNSHIP 1 SOUTH, RANGE 66 WEST OF THE SIXTH PRINCIPAL MERIDIAN, CITY OF BRIGHTON, COUNTY OF ADAMS, STATE OF COLORADO  
SHEET 5 OF 11

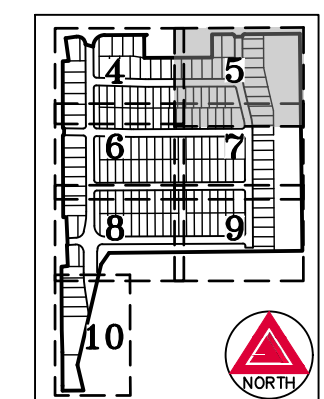
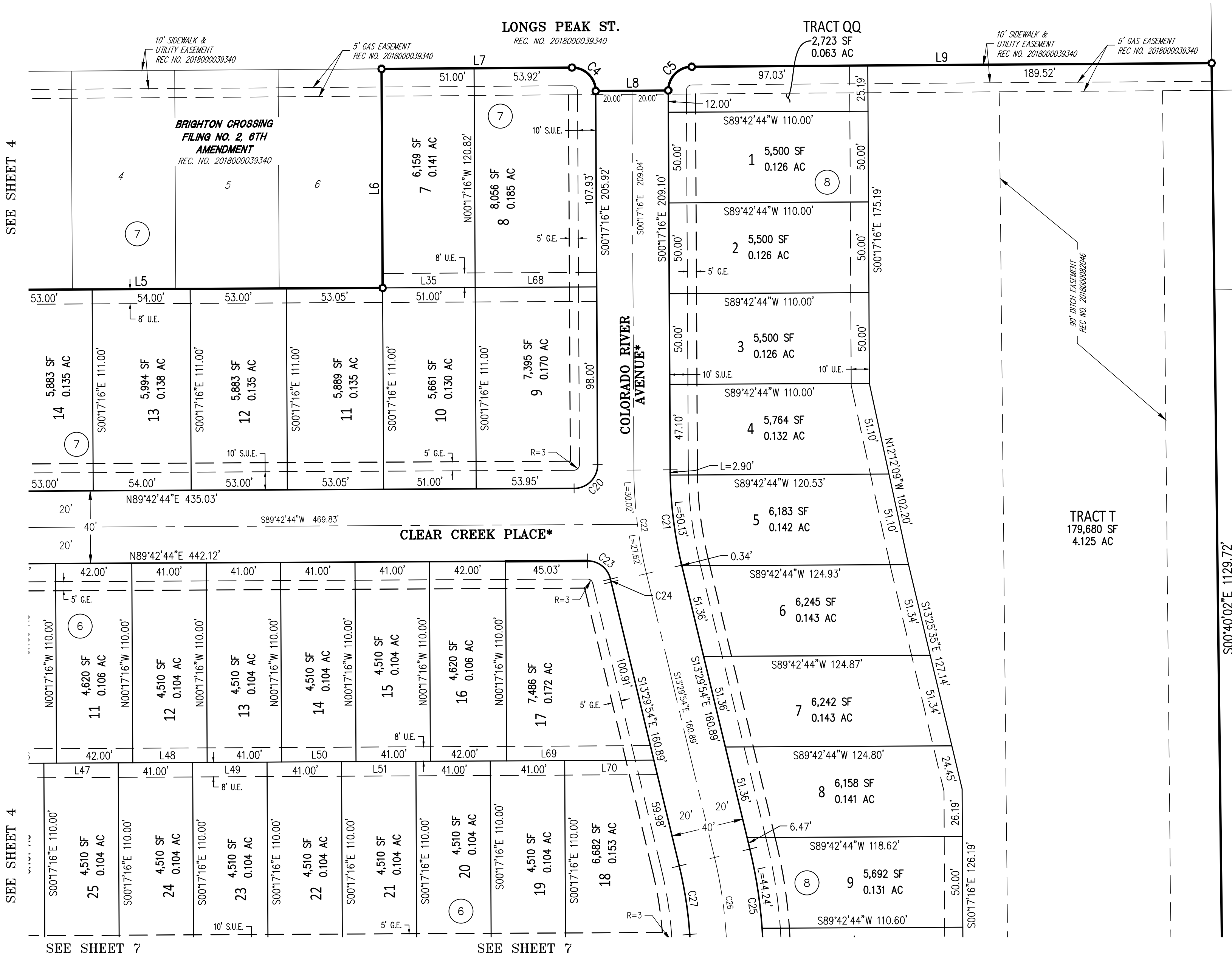

### LEGEND

- SET NO. 5 REBAR WITH 1-1/4" PINK PLASTIC CAP STAMPED "AZTEC LS 38636"
- G.E. GAS EASEMENT
- U.E. UTILITY EASEMENT
- S.U.E. SIDEWALK & UTILITY EASEMENT
- \* 40' WIDE PUBLIC RIGHT-OF-WAY
- R= RADIUS OF UTILITY EASEMENT
- ## BLOCK NUMBER

SEE SHEET 11 FOR LINE & CURVE TABLES

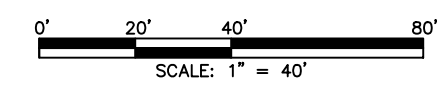
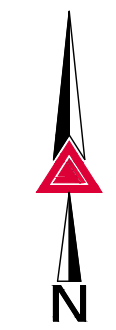

FOR AND ON BEHALF OF  
AZTEC CONSULTANTS, INC.

SEE SHEET 4

SEE SHEET 4

SEE SHEET 7

SEE SHEET 7

**AZTEC**  
CONSULTANTS, INC.  
300 East Mineral Ave., Suite 1  
Littleton, Colorado 80122  
Phone: (303) 713-1898  
Fax: (303) 713-1897  
www.aztecconsultants.com  
Aztec Proj. No.:69718-12

DATE OF PREPARATION:	08-21-2019
SCALE:	1" = 40'
SHEET 5 OF 11	

Drawn By: BAM

# BRIGHTON CROSSING FILING NO. 2, 8TH AMENDMENT

A PORTION OF THE SOUTHEAST QUARTER OF SECTION 2, TOWNSHIP 1 SOUTH, RANGE 66 WEST OF THE SIXTH PRINCIPAL MERIDIAN, CITY OF BRIGHTON, COUNTY OF ADAMS, STATE OF COLORADO

SHEET 6 OF 11

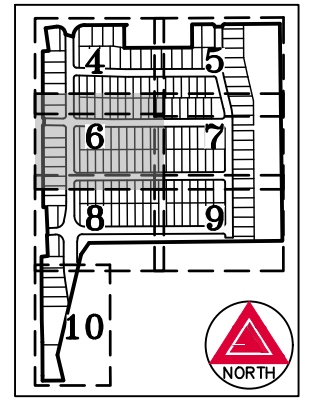

## LEGEND

- SET NO. 5 REBAR WITH 1-1/4" PINK PLASTIC CAP STAMPED "AZTEC LS 38636"
- FOUND NO. 5 REBAR WITH 1-1/4" ORANGE PLASTIC CAP STAMPED "PLS 28286"
- FOUND NO. 5 REBAR WITH NO CAP
- FOUND NO. 5 BENT REBAR WITH NO CAP
- G.E. GAS EASEMENT
- U.E. UTILITY EASEMENT
- S.U.E. SIDEWALK & UTILITY EASEMENT
- \* 40' WIDE PUBLIC RIGHT-OF-WAY
- \*\* PUBLIC RIGHT-OF-WAY WIDTH VARIES
- R= RADIUS OF UTILITY EASEMENT
- ## BLOCK NUMBER

SEE SHEET 11 FOR LINE & CURVE TABLES

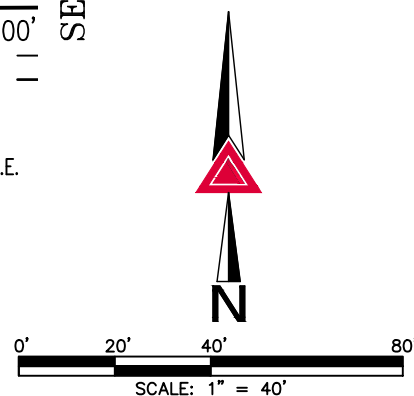

BRIGHTON CROSSING FILING NO. 2 REC. NO. C0902984 FILE 18 MAP NO. 600

SEE SHEET 8

SEE SHEET 7

SEE SHEET 4

SEE SHEET 4

SEE SHEET 7

	DATE OF PREPARATION:	08-21-2019
	SCALE:	1" = 40'
Aztec Proj. No.: 69718-12		SHEET 6 OF 11

FOR AND ON BEHALF OF AZTEC CONSULTANTS, INC.

# BRIGHTON CROSSING FILING NO. 2, 8TH AMENDMENT

A PORTION OF THE SOUTHEAST QUARTER OF SECTION 2, TOWNSHIP 1 SOUTH, RANGE 66 WEST OF THE SIXTH PRINCIPAL MERIDIAN, CITY OF BRIGHTON, COUNTY OF ADAMS, STATE OF COLORADO

SHEET 7 OF 11

SEE SHEET 5

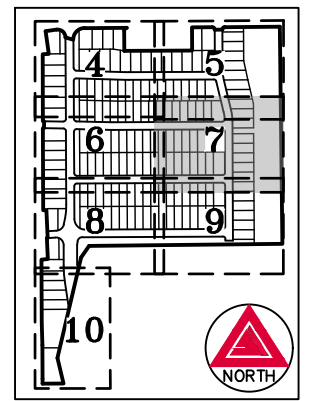

## LEGEND

- 1 FOUND NO. 5 REBAR WITH 1-1/4" ORANGE PLASTIC CAP STAMPED "PLS 28286"
- G.E. GAS EASEMENT
- U.E. UTILITY EASEMENT
- S.U.E. SIDEWALK & UTILITY EASEMENT
- \* 40' WIDE PUBLIC RIGHT-OF-WAY
- R= RADIUS OF UTILITY EASEMENT
- ## BLOCK NUMBER

SEE SHEET 11  
FOR LINE &  
CURVE TABLES

TRACT T  
179,680 SF  
4.125 AC

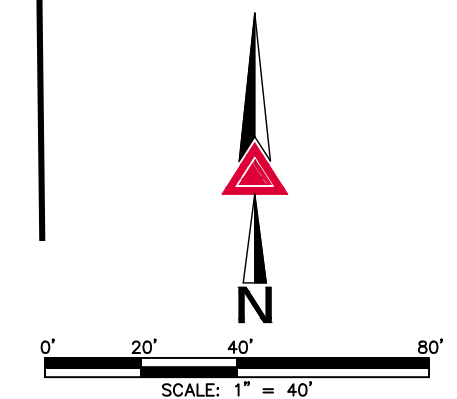

**AZTEC**  
CONSULTANTS, INC.  
300 East Mineral Ave., Suite 1  
Littleton, Colorado 80122  
Phone: (303) 713-1898  
Fax: (303) 713-1897  
www.aztecconsultants.com  
AzTec Proj. No.:69718-12  
Drawn By: BAM

DATE OF PREPARATION:	08-21-2019
SCALE:	1" = 40'
SHEET 7 OF 11	

FOR AND ON BEHALF OF  
AZTEC CONSULTANTS, INC.

# BRIGHTON CROSSING FILING NO. 2, 8TH AMENDMENT

A PORTION OF THE SOUTHEAST QUARTER OF SECTION 2, TOWNSHIP 1 SOUTH, RANGE 66 WEST OF THE SIXTH PRINCIPAL MERIDIAN, CITY OF BRIGHTON, COUNTY OF ADAMS, STATE OF COLORADO

SHEET 8 OF 11

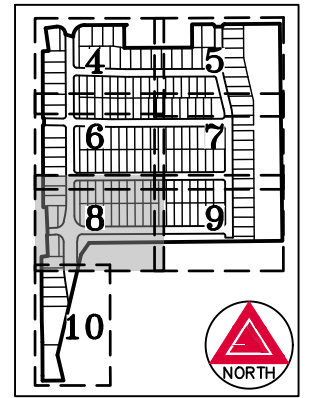
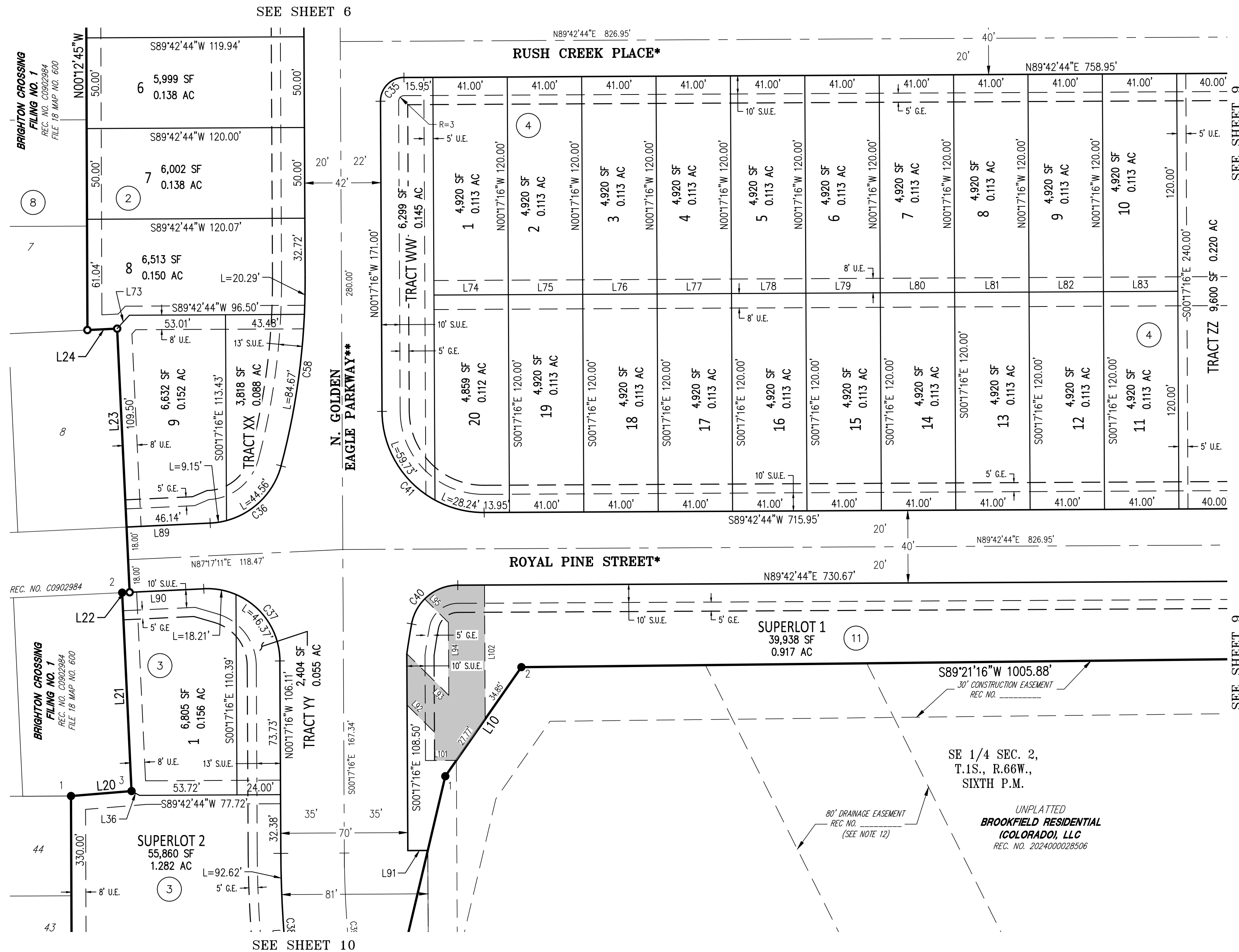

KEY MAP  
SCALE: 1" = 1000'

### LEGEND

- SET NO. 5 REBAR WITH 1-1/4" PINK PLASTIC CAP STAMPED "AZTEC LS 38636"
- FOUND NO. 5 REBAR WITH 1-1/4" ORANGE PLASTIC CAP STAMPED "PLS 28286"
- FOUND NO. 5 REBAR WITH 1-1/4" ORANGE PLASTIC CAP STAMPED "AZTEC LS 38064"
- G.E. GAS EASEMENT
- U.E. UTILITY EASEMENT
- S.U.E. SIDEWALK & UTILITY EASEMENT
- ▭ UTILITY EASEMENT
- \* 40' WIDE PUBLIC RIGHT-OF-WAY
- \*\* PUBLIC RIGHT-OF-WAY WIDTH VARIES
- ## BLOCK NUMBER

SEE SHEET 11  
FOR LINE &  
CURVE TABLES

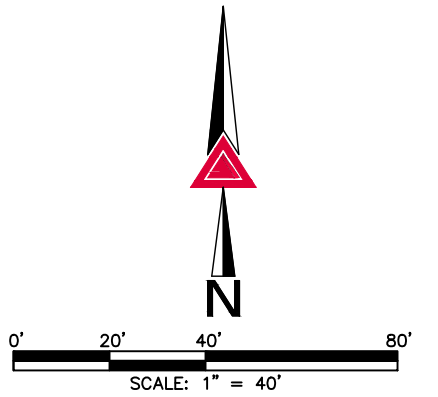

FOR AND ON BEHALF OF  
AZTEC CONSULTANTS, INC.

**AZTEC**  
CONSULTANTS, INC.  
300 East Mineral Ave., Suite 1  
Littleton, Colorado 80122  
Phone: (303) 713-1898  
Fax: (303) 713-1897  
www.aztecconsultants.com  
Aztec Proj. No.: 69718-12

DATE OF PREPARATION:	08-21-2019
SCALE:	1" = 40'
SHEET 8 OF 11	



# BRIGHTON CROSSING FILING NO. 2, 8TH AMENDMENT

A PORTION OF THE SOUTHEAST QUARTER OF SECTION 2, TOWNSHIP 1 SOUTH, RANGE 66 WEST OF THE SIXTH PRINCIPAL MERIDIAN, CITY OF BRIGHTON, COUNTY OF ADAMS, STATE OF COLORADO

SHEET 9 OF 11

SEE SHEET 7

SEE SHEET 7

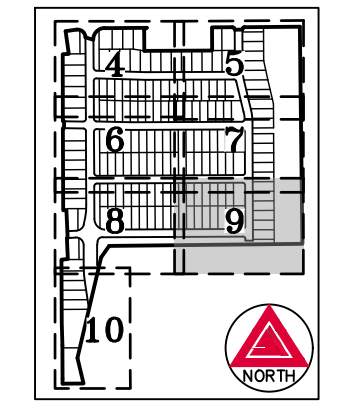
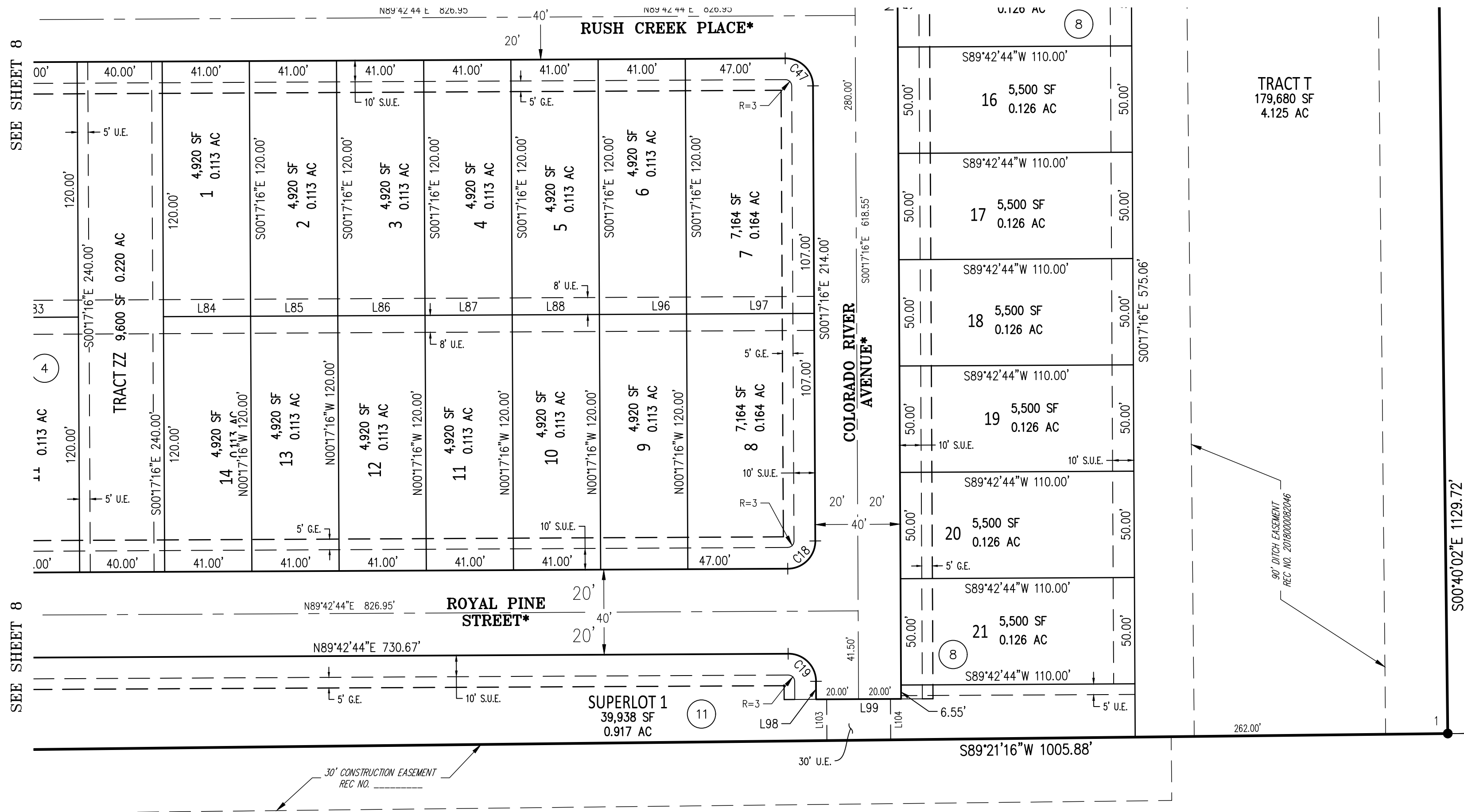

**LEGEND**

- 1 ● FOUND NO. 5 REBAR WITH 1-1/4" ORANGE PLASTIC CAP STAMPED "PLS 28286"
- G.E. GAS EASEMENT
- U.E. UTILITY EASEMENT
- S.U.E. SIDEWALK & UTILITY EASEMENT
- \* 40' WIDE PUBLIC RIGHT-OF-WAY
- R= RADIUS OF UTILITY EASEMENT
- ## BLOCK NUMBER

UNPLATTED  
BROOKFIELD RESIDENTIAL  
(COLORADO), LLC  
REC. NO. 2024000028506

SEE SHEET 11  
FOR LINE &  
CURVE TABLES

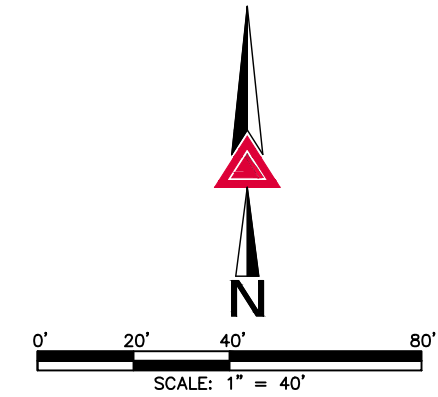

	300 East Mineral Ave., Suite 1 Littleton, Colorado 80122 Phone: (303) 713-1898 Fax: (303) 713-1897 www.aztecconsultants.com	DATE OF PREPARATION: 08-21-2019
	AzTec Proj. No.: 69718-12 Drawn By: BAM	SCALE: 1" = 40' SHEET 9 OF 11

FOR AND ON BEHALF OF  
AZTEC CONSULTANTS, INC

# BRIGHTON CROSSING FILING NO. 2, 8TH AMENDMENT

A PORTION OF THE SOUTHEAST QUARTER OF SECTION 2, TOWNSHIP 1 SOUTH, RANGE 66 WEST OF THE SIXTH PRINCIPAL MERIDIAN, CITY OF BRIGHTON, COUNTY OF ADAMS, STATE OF COLORADO

SHEET 10 OF 11

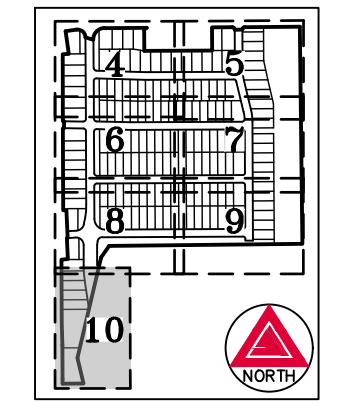
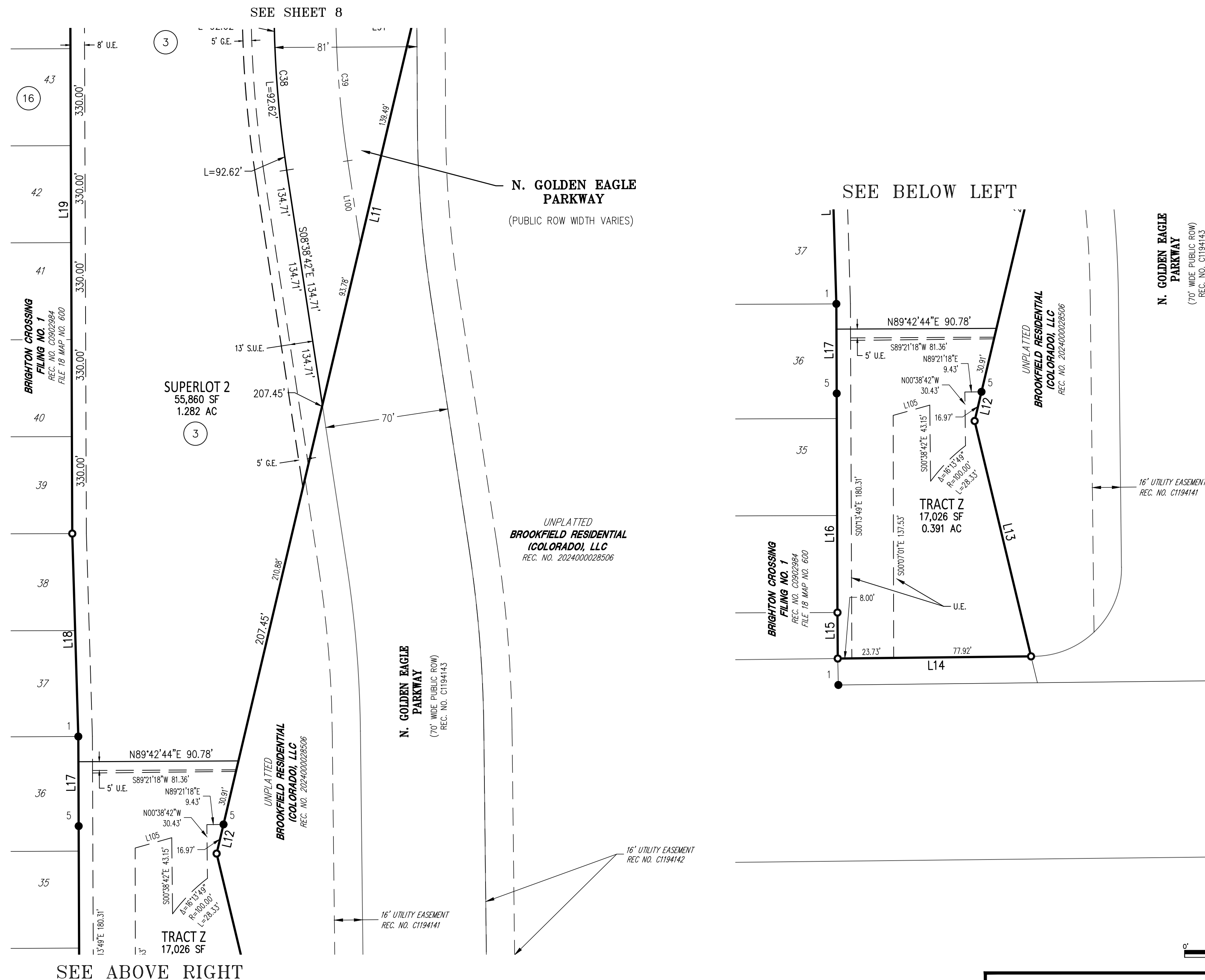

KEY MAP  
SCALE: 1" = 1000'

### LEGEND

- SET NO. 5 REBAR WITH 1-1/4" PINK PLASTIC CAP STAMPED "AZTEC LS 38636"
- FOUND NO. 5 REBAR WITH 1-1/4" ORANGE PLASTIC CAP STAMPED "PLS 28286"
- FOUND NO. 5 REBAR WITH 1-1/4" ORANGE PLASTIC CAP STAMPED "AZTEC LS 38064"
- G.E. GAS EASEMENT
- U.E. UTILITY EASEMENT
- S.U.E. SIDEWALK & UTILITY EASEMENT
- ## BLOCK NUMBER

SEE SHEET 11 FOR LINE & CURVE TABLES

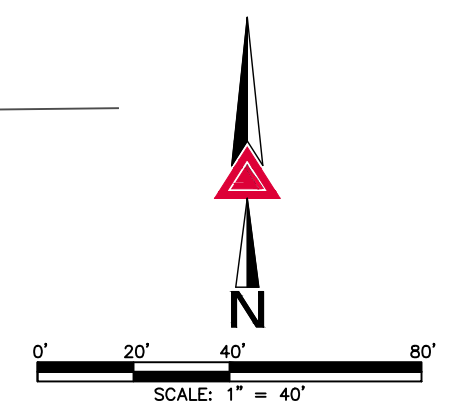

	300 East Mineral Ave., Suite 1 Littleton, Colorado 80122 Phone: (303) 713-1898 Fax: (303) 713-1897 <a href="http://www.aztecconsultants.com">www.aztecconsultants.com</a>	DATE OF PREPARATION: 08-21-2019
	AzTec Proj. No.: 69718-12 Drawn By: BAM	SCALE: 1" = 40' SHEET 10 OF 11

# BRIGHTON CROSSING FILING NO. 2, 8TH AMENDMENT

A PORTION OF THE SOUTHEAST QUARTER OF SECTION 2, TOWNSHIP 1 SOUTH, RANGE 66 WEST OF  
THE SIXTH PRINCIPAL MERIDIAN, CITY OF BRIGHTON, COUNTY OF ADAMS, STATE OF COLORADO

SHEET 11 OF 11

LINE TABLE		
LINE	BEARING	LENGTH
L1	N82°12'47"E	57.27'
L2	S73°42'54"E	41.73'
L3	N89°36'06"E	219.39'
L4	S00°17'16"E	107.07'
L5	N89°42'44"E	353.00'
L6	N00°17'16"W	120.72'
L7	N89°36'06"E	104.92'
L8	N89°31'48"E	40.00'
L9	S89°36'06"W	286.54'
L10	S34°53'38"W	73.28'
L11	S13°16'10"W	536.74'
L12	S13°16'10"W	536.74'
L13	S13°28'57"E	137.26'
L14	S89°21'16"W	109.65'
L15	S00°20'10"E	26.09'
L16	N00°12'45"W	124.22'
L17	N00°12'45"W	50.78'
L18	N01°42'19"W	115.17'
L19	N00°12'45"W	330.00'
L20	N85°18'02"E	33.47'
L21	N02°42'49"W	109.50'
L22	N87°17'11"E	4.15'
L23	N02°42'49"W	145.50'
L24	S87°17'11"W	16.40'
L25	S88°49'07"E	5.52'
L26	N01°10'53"E	36.00'
L27	N88°49'07"W	6.39'
L28	N86°25'05"E	31.82'
L29	N07°47'16"W	119.50'
L30	S89°42'44"W	2.00'

LINE TABLE		
LINE	BEARING	LENGTH
L31	S89°42'44"W	38.95'
L32	S89°42'44"W	37.95'
L33	S89°42'44"W	37.95'
L34	N80°42'22"W	36.45'
L35	N89°42'44"E	51.00'
L36	S61°50'19"E	5.00'
L37	S88°34'10"E	40.07'
L38	S88°34'10"E	40.02'
L39	S88°34'10"E	40.02'
L40	S88°34'10"E	40.02'
L41	S88°34'10"E	40.02'
L42	N89°42'44"E	40.00'
L43	N89°42'44"E	40.00'
L44	N89°42'44"E	40.00'
L45	N89°42'44"E	40.00'
L46	N89°42'44"E	35.00'
L47	N89°42'44"E	34.00'
L48	N89°42'44"E	33.00'
L49	N89°42'44"E	33.00'
L50	N89°42'44"E	33.00'
L51	N89°42'44"E	33.00'
L52	N89°42'44"E	41.00'
L53	N89°42'44"E	41.00'
L54	N89°42'44"E	41.00'
L55	N89°42'44"E	41.00'
L56	N89°36'06"E	38.02'
L57	N89°42'44"E	41.00'
L58	N89°42'44"E	41.00'
L59	N89°42'44"E	41.00'
L60	N89°42'44"E	41.00'

LINE TABLE		
LINE	BEARING	LENGTH
L61	N89°42'44"E	41.00'
L62	N89°42'44"E	41.00'
L63	N89°42'44"E	41.00'
L64	N89°42'44"E	41.00'
L65	N89°42'44"E	41.00'
L66	N89°42'44"E	41.00'
L67	N89°42'44"E	41.00'
L68	N89°42'44"E	66.95'
L69	N89°42'44"E	32.00'
L70	N89°42'44"E	49.15'
L71	N89°42'44"E	41.00'
L72	N89°42'44"E	60.00'
L73	S42°17'11"W	9.98'
L74	N89°42'44"E	41.00'
L75	N89°42'44"E	41.00'
L76	N89°42'44"E	41.00'
L77	N89°42'44"E	41.00'
L78	N89°42'44"E	41.00'
L79	N89°42'44"E	41.00'
L80	N89°42'44"E	41.00'
L81	N89°42'44"E	41.00'
L82	N89°42'44"E	41.00'
L83	N89°42'44"E	41.00'
L84	N89°42'44"E	41.00'
L85	N89°42'44"E	41.00'
L86	N89°42'44"E	41.00'
L87	N89°42'44"E	41.00'
L88	N89°42'44"E	41.00'
L89	S87°17'02"W	46.14'
L90	N87°17'11"E	40.90'

LINE TABLE		
LINE	BEARING	LENGTH
L91	N89°42'43"E	11.00'
L92	N45°17'16"W	21.22'
L93	N45°17'16"W	32.53'
L94	S00°17'17"E	40.13'
L95	S45°17'16"E	18.39'
L96	N89°42'44"E	41.00'
L97	N89°42'44"E	60.00'
L98	S00°17'16"E	8.50'
L99	N89°42'44"E	40.00'
L100	S08°38'42"E	47.71'
L101	S89°42'44"W	17.00'
L102	S00°17'17"E	73.85'
L103	N00°17'16"W	19.41'
L104	N00°17'16"W	19.23'
L105	S74°21'18"W	21.54'

CURVE TABLE			
CURVE	DELTA	RADIUS	LENGTH
C1	97°29'57"	40.81'	69.44'
C2	89°53'23"	59.70'	93.66'
C3	89°53'21"	13.00'	20.40'
C4	90°06'37"	13.00'	20.45'
C5	89°53'15"	13.00'	20.39'
C6	88°00'00"	13.00'	19.97'
C7	1°28'10"	653.30'	16.75'
C8	2°00'00"	500.00'	17.45'
C9	2°00'00"	520.00'	18.15'
C10	92°00'00"	13.00'	20.87'
C11	91°28'10"	13.00'	20.75'
C12	88°31'50"	13.00'	20.09'
C13	91°28'10"	13.00'	20.75'
C14	88°31'50"	13.00'	20.09'
C15	1°28'10"	480.00'	12.31'
C16	1°28'10"	500.00'	12.82'
C17	1°28'10"	520.00'	13.34'
C18	90°00'00"	13.00'	20.42'
C19	90°00'00"	13.00'	20.42'
C20	90°00'00"	13.00'	20.42'

CURVE TABLE			
CURVE	DELTA	RADIUS	LENGTH
C21	13°12'38"	230.00'	53.03'
C22	6°19'50"	250.00'	27.62'
C23	77°08'54"	13.00'	17.50'
C24	0°21'32"	270.00'	1.69'
C25	13°12'38"	270.00'	62.25'
C26	13°12'38"	250.00'	57.64'
C27	9°31'28"	230.00'	38.23'
C28	93°41'10"	13.00'	21.26'
C29	90°00'00"	13.00'	20.42'
C30	90°00'00"	13.00'	20.42'
C31	11°28'01"	50.50'	10.11'
C32	11°28'01"	49.70'	9.95'
C33	11°28'01"	55.50'	11.11'
C34	11°28'01"	44.70'	8.95'
C35	90°00'00"	13.00'	20.42'
C36	72°24'29"	42.50'	53.71'
C37	92°29'58"	40.00'	64.58'
C38	8°21'25"	635.00'	92.62'
C39	8°21'25"	600.00'	87.51'
C40	79°24'19"	26.00'	36.03'

CURVE TABLE			
CURVE	DELTA	RADIUS	LENGTH
C41	90°00'00"	56.00'	87.96'
C42	28°29'52"	14.50'	7.21'
C43	15°11'15"	20.50'	5.43'
C44	17°48'34"	25.50'	7.93'
C45	28°29'52"	9.50'	4.73'
C46	89°59'59"	13.00'	20.42'
C47	90°00'00"	13.00'	20.42'

FOR AND ON BEHALF OF  
AZTEC CONSULTANTS, INC

	300 East Mineral Ave., Suite 1 Littleton, Colorado 80122 Phone: (303) 713-1898 Fax: (303) 713-1897 <a href="http://www.aztecconsultants.com">www.aztecconsultants.com</a>	
	Drawn By: BAM	

DATE OF PREPARATION:	08-21-2019
SCALE:	N/A
SHEET 11 OF 11	